

Product Detail

Flex-C Header

Isometric View

3 Fasteners (Screws or Nails) per block, each side. (For securing desired curve.)

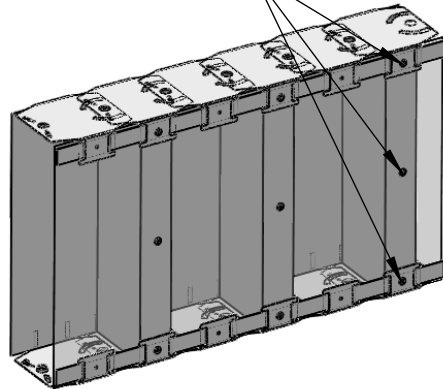

Sectional View

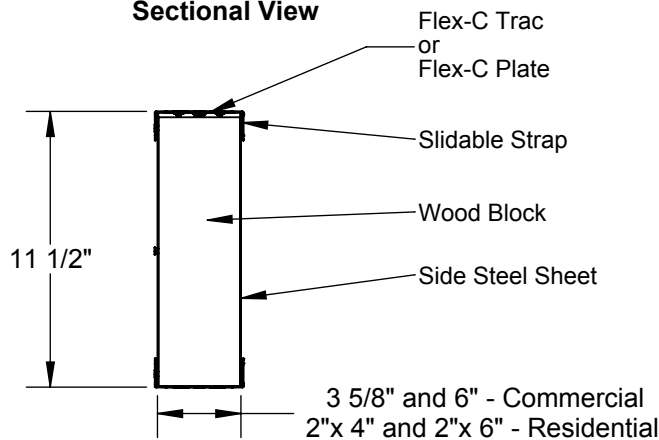

Specifications

Length: 8'

Widths:

For Wood Studs: 2"x4", 2"x6"
For Steel Studs: 3 5/8", and 6"

Minimum Radius: 18"

	Thickness	Grade	Coating/Treatment
Side Steel Sheet	16 Ga.	50	G60 or Better
Flex-C Channel	20 Ga.	33	G60 or Better
Flex-C Strap	0.023"	80	G60 or Better
Wood Blocks Commercial*	1 1/2"	#2	Fire Treated
Wood Blocks Residential*	1 1/2"	#2	-----

** Factory installed inside Flex-C Header*

Recommended Fasteners

Single Openings:

Screws: #10x1 1/4" self drilling ASTM C954-93-Not Provided
Nails: 0.131"x1 1/2" Positive Placement Heat Treated-Not Provided

Multiple Openings:

Screws: #8 x1 1/4" self drilling ASTM C954-93- Provided
Nails: 0.131"x1 1/2" Positive Placement Heat Treated- Not Provided

Note: Please refer to the Flex-C Header cut sheet for installation instructions and proper layout instructions which must be followed.

**FLEX-ABILITY
CONCEPTS**

5500 SW 36th Street
Oklahoma City, OK 73179
Tel: 405-996-5343 Fax: 405-996-5353
E-mail: info@flexabilityconcepts.com
Web: www.flexabilityconcepts.com

Distributor:

Quantity:

Contractor:

Approved By:

Project:

Architect:

Product Detail: PDM35

Date: